

CAMBIA AUTOMATION LIMITED

1794-ACN15

DATASHEET

CAMBIA GROUP

2017

CONTACT EMAIL: SALES@CAMBIA.CN



## FLEX I/O ControlNet Adapter Modules

Cat. No. 1794-ACN15, 1794-ACN15K, 1794-ACNR15, 1794-ACNR15XT, Series D

(1794-ACN15K and 1794-ACNR15XT are conformally coated to meet noxious gas requirements of ISA/ANSI-71.040 1985 Class G3 Environment.)

### Important User Information

Solid state equipment has operational characteristics differing from those of electromechanical equipment. Safety Guidelines for the Application, Installation and Maintenance of Solid State Controls (Publication [SGI-1.1](#) available from your local Rockwell Automation sales office or online at <http://literature.rockwellautomation.com>) describes some important differences between solid state equipment and hard-wired electromechanical devices. Because of this difference, and also because of the wide variety of uses for solid state equipment, all persons responsible for applying this equipment must satisfy themselves that each intended application of this equipment is acceptable.

In no event will Rockwell Automation, Inc. be responsible or liable for indirect or consequential damages resulting from the use or application of this equipment.

The examples and diagrams in this manual are included solely for illustrative purposes. Because of the many variables and requirements associated with any particular installation, Rockwell Automation, Inc. cannot assume responsibility or liability for actual use based on the examples and diagrams.

No patent liability is assumed by Rockwell Automation, Inc. with respect to use of information, circuits, equipment, or software described in this manual.

Reproduction of the contents of this manual, in whole or in part, without written permission of Rockwell Automation, Inc. is prohibited.

Throughout this manual we use notes to make you aware of safety considerations.

	<b>WARNING</b> Identifies information about practices or circumstances that can cause an explosion in a hazardous environment, which may lead to personal injury or death, property damage, or economic loss.
	<b>IMPORTANT</b> Identifies information that is critical for successful application and understanding of the product.
	<b>ATTENTION</b> Identifies information about practices or circumstances that can lead to personal injury or death, property damage, or economic loss. Attentions help you to identify a hazard, avoid a hazard, and recognize the consequences.
	<b>SHOCK HAZARD</b> Labels may be on or inside the equipment, for example, a drive or motor, to alert people that dangerous voltage may be present.
	<b>BURN HAZARD</b> Labels may be on or inside the equipment, for example, a drive or motor, to alert people that surfaces may reach dangerous temperatures.

### ATTENTION



### Environment and Enclosure

This equipment is intended for use in a Pollution Degree 2 industrial environment, in overvoltage Category II applications (as defined in IEC 60664-1), at altitudes up to 2000 m (6562 ft) without derating.

This equipment is considered Group 1, Class A industrial equipment according to IEC/CISPR 11. Without appropriate precautions, there may be difficulties with electromagnetic compatibility in residential and other environments due to conducted and radiated disturbances.

This equipment is supplied as open-type equipment. It must be mounted within an enclosure that is suitably designed for those specific environmental conditions that will be present and appropriately designed to prevent personal injury resulting from accessibility to live parts. The enclosure must have suitable flame-retardant properties to prevent or minimize the spread of flame, complying with a flame spread rating of 5VA, V2, V1, V0 (or equivalent) if non-metallic. The interior of the enclosure must be accessible only by the use of a tool. Subsequent sections of this publication may contain additional information regarding specific enclosure type ratings that are required to comply with certain product safety certifications.

In addition to this publication, see:

- Industrial Automation Wiring and Grounding Guidelines, Rockwell Automation publication [1770-4.1](#), for additional installation requirements.
- NEMA Standard 250 and IEC 60529, as applicable, for explanations of the degrees of protection provided by different types of enclosure.

### WARNING



If you insert or remove the module while backplane power is on, or connect or disconnect the ControlNet cable (BNC or NAP) with power applied to the module or any device on the network, an electrical arc can occur. This could cause an explosion in hazardous location installations.

Be sure that power is removed or the area is nonhazardous before proceeding.

### WARNING



If you connect or disconnect wiring while the field side power is on, an electrical arc can occur. This could cause an explosion in hazardous location installations. Be sure that power is removed or the area is nonhazardous before proceeding.

### WARNING



The Network Access Port (NAP) is intended for temporary local programming purposes only and not intended for permanent connection. If you connect or disconnect the NAP cable with power applied to this module or any device on the network, an electrical arc can occur. This could cause an explosion in hazardous location installations.

Be sure that power is removed or the area is nonhazardous before proceeding.

### ATTENTION



FLEX I/O is grounded through the DIN rail to chassis ground. Use zinc plated yellow-chromate steel DIN rail to assure proper grounding. The use of other DIN rail materials (for example, aluminum or plastic) that can corrode, oxidize, or are poor conductors, can result in improper or intermittent grounding. Secure DIN rail to mounting surface approximately every 200 mm (7.8 in.) and use end-anchors appropriately.

### ATTENTION



Personnel responsible for the application of safety-related programmable electronic systems (PES) shall be aware of the safety requirements in the application of the system and shall be trained in using the system.

**ATTENTION** Do not remove or replace an adapter module while power is applied. Interruption of the backplane can result in unintentional operation or machine motion.

**ATTENTION** To reduce susceptibility to noise, power communications adapter modules and I/O modules from separate power supplies.

**ATTENTION** To comply with the CE Low Voltage Directive (LVD), this equipment must be powered from a source compliant with the following:  
Safety Extra Low Voltage (SELV) or Protected Extra Low Voltage (PELV).

**ATTENTION** **Prevent Electrostatic Discharge**  
This equipment is sensitive to electrostatic discharge, which can cause internal damage and affect normal operation. Follow these guidelines when you handle this equipment:

- Touch a grounded object to discharge potential static.
- Wear an approved grounding wriststrap.
- Do not touch connectors or pins on component boards.
- Do not touch circuit components inside the equipment.
- Use a static-safe workstation, if available.
- Store the equipment in appropriate static-safe packaging when not in use.

**WARNING** For Class I Division 2 applications, use only Class I Division 2 listed or recognized accessories and modules approved for used within the 1794 platform.

**European Hazardous Location Approval**

The following adapters are European Zone 2 approved: 1794-ACN15, 1794-ACN15K, 1794-ACNR15, 1794-ACNR15XT, Series D.

**The following applies when the product bears the Ex Marking**

This equipment is intended for use in potentially explosive atmospheres as defined by European Union Directive 94/9/EC and has been found to comply with the Essential Health and Safety Requirements relating to the design and construction of Category 3 equipment intended for use in Zone 2 potentially explosive atmospheres, given in Annex II to this Directive.  
Compliance with the Essential Health and Safety Requirements has been assured by compliance with EN 60079-15 and EN 60079-0.

**WARNING** Observe the following additional Zone 2 certification requirements:

- This equipment is not resistant to sunlight or other sources of UV radiation
- This equipment must be installed in an enclosure providing at least IP54 protection when applied in Zone 2 environments.
- This equipment shall be used within its specified ratings defined by Rockwell Automation.
- Provision shall be made to prevent the rated voltage from being exceeded by transient disturbances of more than 40% when applied in Zone 2 environments.
- Secure any external connections that mate to this equipment by using screws, sliding latches, threaded connectors, or other means provided with this product.
- Do not disconnect equipment unless power has been removed or the area is known to be nonhazardous.

**North American Hazardous Location Approval**

The following adapters are North American Hazardous Location approved: 1794-ACN15, 1794-ACN15K, 1794-ACNR15, 1794-ACNR15XT, Series D

The following information applies when operating this equipment in hazardous locations:		Informations sur l'utilisation de cet équipement en environnements dangereux :	
Products marked "CL I, DIV 2, GP A, B, C, D" are suitable for use in Class I Division 2 Groups A, B, C, D, Hazardous Locations and nonhazardous locations only. Each product is supplied with markings on the rating nameplate indicating the hazardous location temperature code. When combining products within a system, the most adverse temperature code (lowest "T" number) may be used to help determine the overall temperature code of the system. Combinations of equipment in your system are subject to investigation by the local Authority Having Jurisdiction at the time of installation.		Les produits marqués "CL I, DIV 2, GP A, B, C, D" ne conviennent qu'à une utilisation en environnements de Classe I Division 2 Groupes A, B, C, D dangereux et non dangereux. Chaque produit est livré avec des marquages sur sa plaque d'identification qui indiquent le code de température pour les environnements dangereux. Lorsque plusieurs produits sont combinés dans un système, le code de température le plus défavorable (code de température le plus faible) peut être utilisé pour déterminer le code de température global du système. Les combinaisons d'équipements dans le système sont sujettes à inspection par les autorités locales qualifiées au moment de l'installation.	
<b>WARNING</b>	<b>EXPLOSION HAZARD</b> • Do not disconnect equipment unless power has been removed or the area is known to be nonhazardous. • Do not disconnect connections to this equipment unless power has been removed or the area is known to be nonhazardous. Secure any external connections that mate to this equipment by using screws, sliding latches, threaded connectors, or other means provided with this product. • Substitution of components may impair suitability for Class I, Division 2. • If this product contains batteries, they must only be changed in an area known to be nonhazardous.	<b>AVERTISSEMENT</b>	<b>RISQUE D'EXPLOSION</b> • Couper le courant ou s'assurer que l'environnement est classé non dangereux avant de débrancher l'équipement. • Couper le courant ou s'assurer que l'environnement est classé non dangereux avant de débrancher les connecteurs. Fixer tous les connecteurs externes reliés à cet équipement à l'aide de vis, loquets coulissants, connecteurs filetés ou autres moyens fournis avec ce produit. • La substitution de composants peut rendre cet équipement inadapté à une utilisation en environnement de Classe I, Division 2. • S'assurer que l'environnement est classé non dangereux avant de changer les piles.

**ControlNet Adapter, 1794-ACN15, 1794-ACN15K, 1794-ACNR15, 1794-ACNR15XT, Series D**

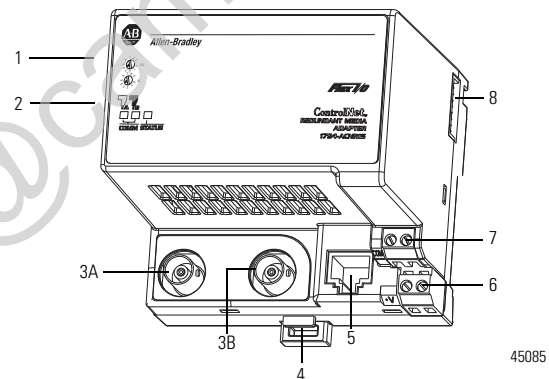

**Component Identification**

1	ControlNet Node selection dial	5	ControlNet programming terminal network access port (NAP)
2	Indicators	6	+24V DC connections
3A	ControlNet network cable BNC connector A	7	24V common connections
3B	ControlNet network cable BNC connector B (1794-ACNR15, 1794-ACNR15XT only)	8	FlexBus connector
4	Module locking tab		

1794-ACN15(K), 1794-ACNR15(XT) Series D, Firmware Revision 10.2, of the FLEX I/O ControlNet Single and Redundant adapters function as drop-in replacements for the series C adapters and continue to support 32-bit modules and numerical display of the firmware revision in RSNetWorx for ControlNet (Revision 3.21 or later).

### Install Your ControlNet

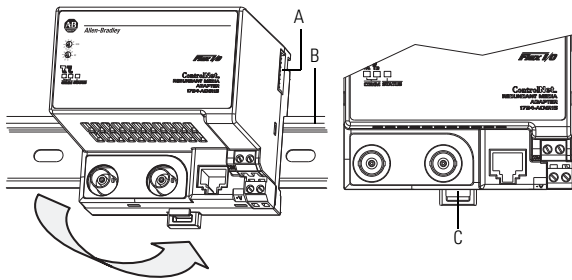

45086

**ATTENTION**

During mounting of all devices, be sure that all debris (for example, metal chips, wire strands) is kept from falling into the module. Debris that falls into the module could cause damage on power up.



### Mounting Dimensions

The module has the following mounting dimensions.

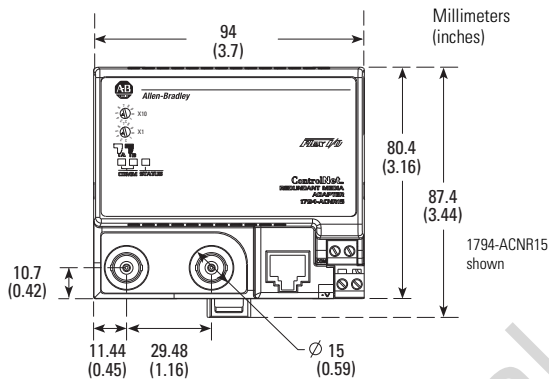

45091

HxWxD:  
87.4 x 94 x 92 mm  
(3.44 x 3.7 x 3.6 in.)

### Mount on a DIN Rail

1. Position the ControlNet adapter module (A) on an IEC standard (35 x 7.5 x 1 mm) top-hat DIN rail, Allen-Bradley part number 199-DR1; 46277-3; EN50022 (B), at a slight angle.
2. Hook the lip on the rear of the adapter onto the top of the DIN rail, and rotate the adapter module onto the rail.
3. Press the adapter module down onto the DIN rail until flush. Locking tab C snaps the adapter into position and locks it onto the DIN rail.
4. If the adapter module does not lock in place, use a screwdriver or similar device to move the locking tab down while pressing the adapter module flush onto the DIN rail, and release the locking tab to lock the adapter module in place. If necessary, push up on the locking tab to lock.
5. Connect the adapter wiring as shown in the section, Connecting Wiring.

### Mount on a Panel or Wall

If mounting this adapter to a panel or wall, refer to publication [1794-2.13](#), Panel Mounting Kit, Cat. No. 1794-NM1.

### Mount or Replace the Adapter on an Existing System

1. Disconnect any wiring jumpered to the adjacent terminal base.

2. Disconnect the BNC connector(s) from the front of the adapter.

**WARNING**



If you connect or disconnect the communications cable with power applied to this module or any device on the network, an electrical arc can occur. This could cause an explosion in hazardous location installations. Be sure that power is removed or the area is nonhazardous before proceeding.

3. Open the module latching mechanism and remove the module from the base unit to which the adapter will be attached.
4. Push the FlexBus connector toward the right side of the terminal base to unplug the backplane connection.

**WARNING**



If you insert or remove the module while backplane power is on, an electrical arc can occur. This could cause an explosion in hazardous location installations. Be sure that power is removed or the area is nonhazardous before proceeding.

5. Release the locking tab and remove the adapter module.

Before installing the new adapter, notice the notch on the right rear of the adapter. This notch accepts the hook on the terminal base unit. The notch is open at the bottom. The hook and adjacent connection point keep the terminal base and the adapter tight together, reducing the possibility of a break in communication over the backplane.



6. Complete the adapter mounting as shown below.

Push down and in at the same time to lock the adapter to the DIN rail. If the adapter does not lock in place, use a screwdriver or similar device to move the locking tab down while pressing the adapter flush onto the DIN rail, and release the locking tab to lock the adapter module in place. If necessary, push up on the locking tab to lock.

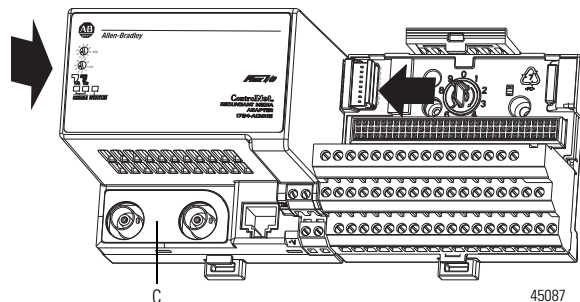

45087

When the adapter is locked onto the DIN rail, gently push the FlexBus connector into the adapter to complete the backplane

7. Reinstall the module in the adjacent terminal base unit.

**Connecting Wiring**

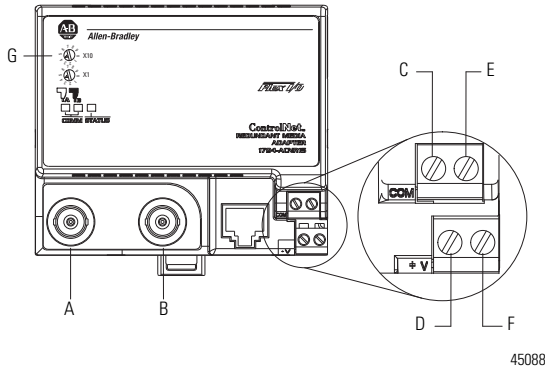

1. Connect the ControlNet network cable to connector, terminal A.
2. For 1794-ACNR15, 1794-ACNR15XT only: Connect the redundant ControlNet network cable to connector B.

**WARNING**

If you connect or disconnect the ControlNet cable with power applied to this module or any device on the network, an electrical arc can occur. This could cause an explosion in hazardous installations. Be sure that power is removed or the area is nonhazardous before proceeding.

**WARNING**

If you connect or disconnect wiring while the field side power is on, an electrical arc can occur. This could cause an explosion in hazardous location installations. Be sure that power is removed or the area is nonhazardous before proceeding.

**ATTENTION**

- When connecting wiring, torque terminal screws C, D, E and F to 0.8 Nm (7 lb-in).
- Power wiring must be less than 10 meters (32.8 ft) in length.
- Do not wire more than 2 conductors on any single terminal.

3. Connect +V DC power to the left side of the lower connector, terminal D.
4. Connect -V common to the left side of the upper connector, terminal C.
5. Connections E and F are used to pass +V DC power (F) and -V common (E) to the next module in the series (if required).
6. Set the network address using the selection dials G. Valid settings range from 01...99.



**Indicators**

The module has LED indicators to specify its status and aid the user in troubleshooting.

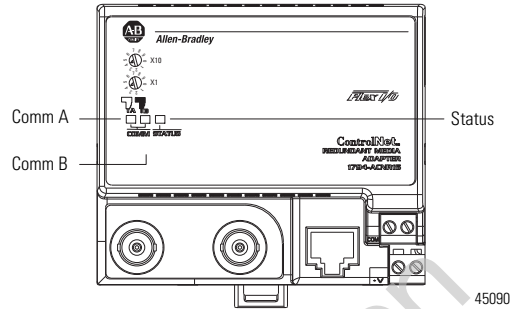

**LED Indicators**

LED Indications	Probable Cause
<b>Comm A and Comm B Simultaneously</b>	
Off	No power, or reset
Red	Adapter inoperative
Red/Green – flashing alternately	Adapter self-test
Red/Off – flashing alternately	Bad node configuration (duplicate address)
<b>Comm A or Comm B (individually)</b>	
Off	Channel disabled
Green	Channel operational
Flashing green/Off	Temporary network errors
Flashing red/Off	Cable fault, broken cable, redundancy warning
Flashing red/green	Bad network configuration
<b>Status Indicator</b>	
Off	No power
Flashing green/off	On-line but not connected
Green	On-line, link OK, connected
Flashing red	I/O module removed, wrong I/O module inserted, FLASH program update in progress
Red	Critical – adapter failure

**Specifications**

**General**

Attribute	Value
I/O capacity	8 modules
Supply voltage	Input: 19.2...31.2V DC, 400 mA Output: 5V DC, 640 mA
Inrush current	14 A for 2 ms
Communication rate	5 Mbps
Indicators	I/O Status – red/green Comm A – red/green Comm B – red/green
Isolation voltage	50V (continuous), Basic Insulation Type Type tested @ 860 V AC for 60 s, power to system, power to ControlNet, and ControlNet to system No isolation between ControlNet channels
Power dissipation, max	3.4 W @ 19.2V DC
Terminal screw torque	0.8 Nm (7 lb-in.)

**General**

Wire size	Power connections: Single wire connection: 0.33... 2.5 mm <sup>2</sup> (22...12 AWG) solid or stranded copper wire rated at 75 °C (167 °F) or greater 1.2 mm (3/64 in.) insulation max  Double wire connection: 0.33... 1.3 mm <sup>2</sup> (22...16 AWG) solid or stranded (not intermixed) copper wire rated at 75 °C (167 °F) or greater 1.2 mm (3/64 in.) insulation max
Wiring Category <sup>(1)</sup>	3 – on power ports 2 – on communications ports
North American temp code	T4A
IEC temp code	T4
Enclosure Type Rating	None (open-style)
ControlNet Cable	Belden RG-6/U
Weight	220 g (7.76 oz)
Dimensions HxWxD	87.4 x 94 x 92 mm (3.44 x 3.7 x 3.6 in.)

<sup>(1)</sup> Use this Conductor Category information for planning conductor routing. Refer to Industrial Automation Wiring and Grounding Guidelines, publication 1770-4.1.

**Environmental**

Attribute	Value
Temperature, operating	IEC 60068-2-1 (Test Ad, Operating Cold), IEC 60068-2-2 (Test Bd, Operating Dry Heat), IEC 60068-2-14 (Test Nb, Operating Thermal Shock): -25...55 °C (-13...131 °F) -25...70 °C (-13...158 °F) – <b>1794-ACNR15XT</b>
Temperature, surrounding air, max	55 °C (131 °F) 70 °C (158 °F) – <b>1794-ACNR15XT</b>
Temperature, nonoperating	IEC 60068-2-1 (Test Ab, Un-packaged Non-operating Cold), IEC 60068-2-2 (Test Bb, Un-packaged Non-operating Dry Heat), IEC 60068-2-14 (Test Na, Un-packaged Non-operating Thermal Shock): -40...85 °C (-40...185 °F)
Relative humidity	IEC 60068-2-30 (Test Db, Unpackaged Damp Heat): 5...95% non-condensing
Vibration	IEC60068-2-6 (Test Fc, Operating): 5 g @ 10...500 Hz
Shock, operating	IEC 60068-2-27 (Test Ea, Unpackaged Shock): 30 g
Shock, nonoperating	IEC 60068-2-27 (Test Ea, Unpackaged Shock): 50 g
Emissions	CISPR 11: Group 1, Class A
ESD immunity	IEC 61000-4-2: 6 kV contact discharges 8 kV air discharges
Radiated RF immunity	IEC 61000-4-3: 10V/m with 1 kHz sine-wave 80% AM from 80...2000 MHz 10V/m with 200 Hz 50% Pulse 100% AM at 900 MHz 10V/m with 200 Hz 50% Pulse 100% AM at 1890 MHz 3V/m with 1 kHz sine-wave 80% AM from 2000...2700 MHz
EFT/B immunity	IEC 61000-4-4: ±2 kV at 5 kHz on power ports ±2 kV at 5 kHz on communications ports
Surge transient immunity	IEC 61000-4-5: ±2 kV line-earth(CIM) on communications ports
Conducted RF immunity	IEC 61000-4-6: 10V rms with 1 kHz sine-wave 80% AM from 150 kHz...80 MHz

**Certifications (when product is marked)<sup>(1)</sup>**

Attribute	Value
c-UL-us	UL Listed Industrial Control Equipment, certified for US and Canada. See UL File E65584.  UL Listed for Class I, Division 2 Group A,B,C,D Hazardous Locations, certified for U.S. and Canada. See UL File E194810.
CE	European Union 2004/108/EC EMC Directive, compliant with: EN 61326-1; Meas./Control/Lab., Industrial Requirements EN 61000-6-2; Industrial Immunity EN 61000-6-4; Industrial Emissions EN 61131-2; Programmable Controllers (Clause 8, Zone A & B)
C-Tick	Australian Radiocommunications Act, compliant with: AS/NZS CISPR 11; Industrial Emissions

**Certifications (when product is marked)<sup>(1)</sup>**

Ex	European Union 94/9/EC ATEX Directive, compliant with: EN 60079-15; Potentially Explosive Atmospheres, Protection "n" EN 60079-0; General Requirements II 3 G Ex nA IIC T4 X
TÜV	TÜV Certified for Functional Safety: Capable of SIL 2
CI	ControlNet Int'l conformance tested to ControlNet specifications

<sup>(1)</sup> See the Product Certification link at <http://www.ab.com> for Declaration of Conformity, Certificates, and other certification details.

Email: sales@cambia.cn

Rockwell Otomasyon Ticaret A.Ş., Kar Plaza İş Merkezi E Blok Kat:6 34752 İçerenköy, İstanbul, Tel: +90 (216) 5698400

**[www.rockwellautomation.com](http://www.rockwellautomation.com)**

---

**Power, Control and Information Solutions Headquarters**

Americas: Rockwell Automation, 1201 South Second Street, Milwaukee, WI 53204-2496 USA, Tel: (1) 414.382.2000, Fax: (1) 414.382.4444

Europe/Middle East/Africa: Rockwell Automation, Vorstlaan/Boulevard du Souverain 36, 1170 Brussels, Belgium, Tel: (32) 2 663 0600, Fax: (32) 2 663 0640

Asia Pacific: Rockwell Automation, Level 14, Core F, Cyberport 3, 100 Cyberport Road, Hong Kong, Tel: (852) 2887 4788, Fax: (852) 2508 1846

Publication 1794-IN128E-EN-P - March 2011

Supersedes Publication 1794-IN128D-EN-P - January 2011

PN-108483

Copyright © 2011 Rockwell Automation, Inc. All rights reserved.